

Mounting Holes, Ø7
2 nos

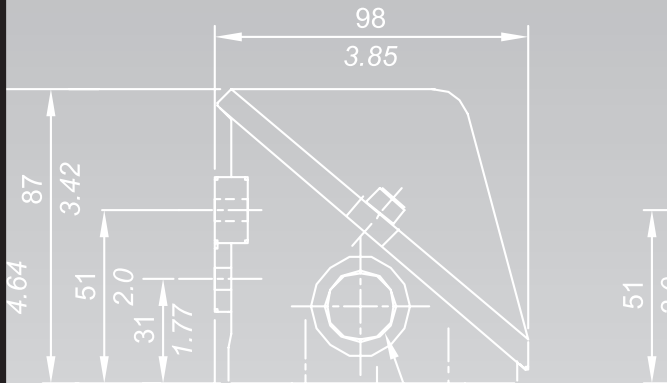

**PRESSURE SWITCHES
PRESSURE DIFFERENCE SWITCHES
VACUUM SWITCHES
TEMPERATURE SWITCHES**
From 1.5 mbar to 600 bar



MT Temperature Switch

INSTALLATION AND OPERATING INSTRUCTIONS



Kaustubha Udyog (Orion Instruments)

S. No. 36/1/1, Sinhgad Road, Vadgaon Khurd, Pune 411 041 INDIA
Tel.: +91-(0) 20-24393877
Telefax : +91-(0) 20-24393577 / 25460486
Email : ku.pressure@gmail.com

Certificate No.: FM72815



Website : www.orion-instruments.io

Installation and Operating Instructions for MT Temperature Switch

CONSTRUCTION:

MT series temperature switch is a pressure switch actuated by vapour pressure which is directly proportional to the temperature being sensed. The switch is housed in a tough Aluminium housing fitted on a stainless steel base, retained by SS screws. A calibrated scale, as also the working of the switch is visible if the cover is removed. The temperature switch consists of a Aluminium housing, a junction cylinder (aluminium/SS), a disc nylon reinforced rubber/metal diaphragm and a plunger. For temperature switch, a temperature sensing capsule comprising a capillary and a temperature bulb is used. The temperature being sensed by the bulb, changes the vapour pressure of the liquid filled in the capillary. This is converted to a force which is balanced by a spring in the junction cylinder. When the force generated by the vapour pressure exceeds/falls above / below the spring force, a microswitch housed in the enclosure is actuated by a transfer rod.

A separate terminal strip with screwed ends is provided for easy wiring. The cable gland provided is M20 x 1.5 standard and 1/2" NPT / 3/8" NPT / 3/8" BSP.

PRINCIPLE OF OPERATION:

Temperature being sensed by the bulb is in direct proportion to the pressure of the liquid filled in the

temperature sensing capsule. As the temperature being sensed changes, so does the vapour pressure inside the bulb. This change in pressure is sensed by a diaphragm, a calibrated piston and a compression spring. Once the pressure changes beyond the set limit, an operating rod actuates a microswitch(es) inside the housing.

INSTALLATION:

WARNING

Your attention, is drawn to the electrical potential that will be present, if the main cover is removed while the switch is connected to a live supply. The electrical supply **MUST BE ISOLATED** prior to removal of the cover.

Please ensure that the bulb is preferably vertical and below the capillary. The switch unit though can be mounted in any direction. Use a location free from excessive vibration, shock or temperature fluctuation. Heat transfer from vicinity or adjacent process lines could affect working of the unit.

The unit must be specified, installed and operated by competent personnel, & its use be limited to within the published specifications. Unauthorized modifications repair or operation outside the specified limits may invalidate the warranty. Servicing should only be carried out by qualified personnel.

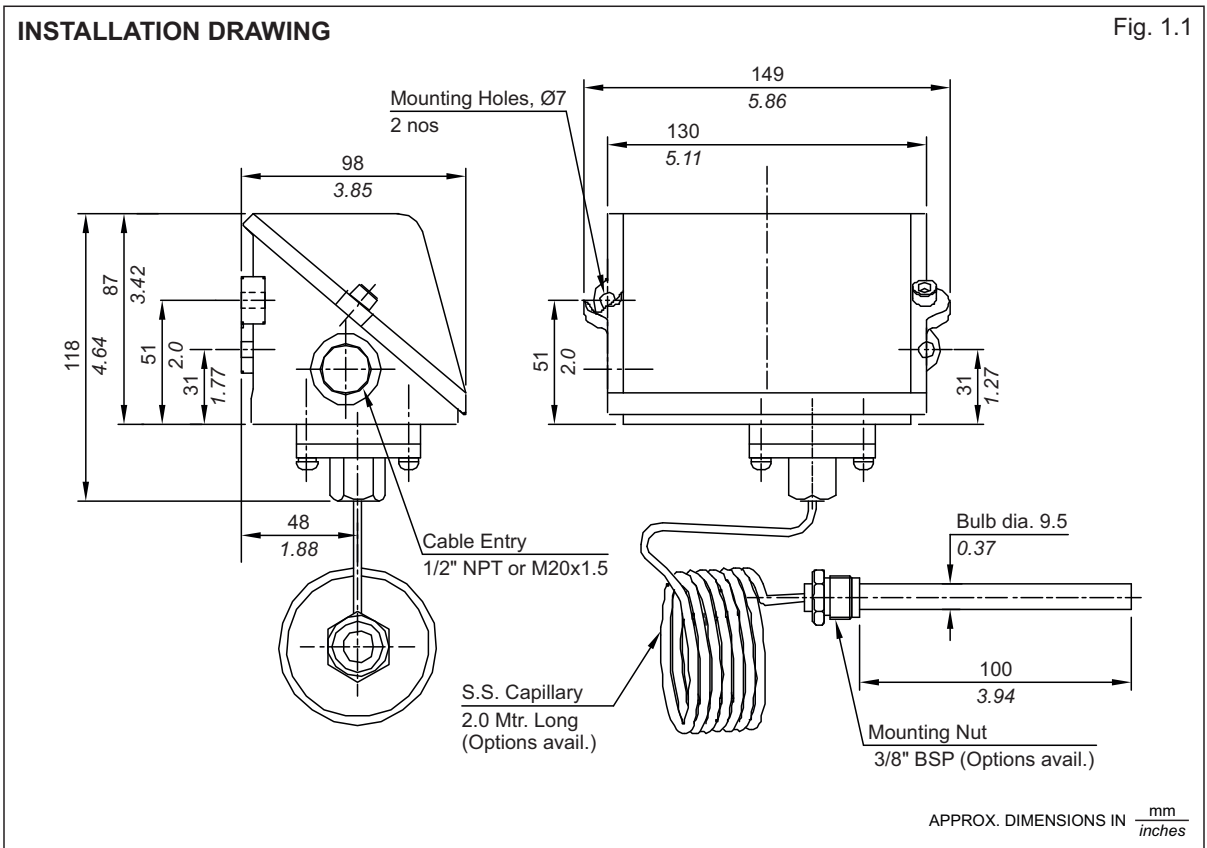

FAILURE HAZARD

Temperature switches element/primary seal failure.

The process medium temperature should not be allowed to exceed that stated in the product data & under the "OPERATING TEMPERATURES" section in this document.

Excessive bending of the capillary, resulting in cracking it, may render the switch inoperable. Ensure the bulb material is compatible to the sensing medium and can sustain pressure of the working medium. When this is not the case, use a thermowell of appropriate material and rating.

PROCESS CONNECTIONS

The remote bulb is of brass and the capillary is provided with a 1/2" NPT(M) (Options Available) gland nut. Using this gland nut, a thermowell of appropriate size, rating and material can be used to suit the process whose temperature is to be sensed. Thermowells can be provided as accessories, if the specifications are provided by the end user/ customer.

MATERIALS

The materials used in this switch are as follows,

The housing - Aluminium / Stainless Steel

Internal switch mechanism – S.S. / M.S. / Al

External Fasteners – S.S. / M.S.

Internal Fasteners & Springs – S.S. / M.S.

Temperature Bulb – Brass / S.S.

Capillary – S.S.

MOUNTING

The temperature switch can be mounted in any direction.

- 1) The temperature switch can be mounted directly in case the mounting is rigid.
- 2) For panel mounting, use M6 bolts of appropriate length through the mounting holes. If the equipment is subject to vibration, please use the rubber washer / pads between the panel and the switch.
- 3) For pipe mounting, use a pipe mounting bracket that can be provided along with the temperature switch, to clamp the switch on to the pipe.
- 4) Thermowell can be provided as per requirement.

CAUTION : Please ensure that the bulb is preferably vertical and below the capillary. The switch unit though can be mounted in any direction.

FAILURE HAZARD: The copper capillary is used for filling volatile liquid. It should not be bent such that it develops a crack or is broken. The switch will not function after such an event. The length of copper capillary is purposely kept more in the event the sensing temperature capsule has to be refilled.

ELECTRICAL CONNECTIONS:

Temperature switches will generally have only one SPDT microswitch.

Temperature switches with 2 SPDT microswitches can also be provided on demand.

All models are normally supplied with a straight M20 conduit entry provided on either side of the switch and either one can be plugged, if not in use. These conduit connections can be fitted either with a suitable gland or directly with conduit to suit the installation.

CAUTION : It is a safety requirement that at least 5 full threads must be engaged. Use only cable glands and plugs certified for use in hazardous area.

Access to the terminal is via a removable top cover. The electrical supply must be isolated prior to this activity. Switch connections details are provided on the cover (name plate). This should be referred to when connecting it to the terminal strip as NO/NC. Terminal numbers vary depending on whether switch setting is falling or rising.

Terminals are suitable for cables, single or multi strand, up to 2.5 sq mm. When 2 SPDT microswitches are fitted, they are mechanically linked to give a DPDT switching action.

Reset of the switches could be up to 3% apart due to the inherent differential of microswitches. For specific wiring, refer the figure.

WIRING:

a) Your attention is drawn to the electrical potential that will be present, if the main cover is removed while the switch is connected to a live supply. The electrical supply must be isolated prior to removal of the cover.

b) Remove the cover.

c) Pass the cable through the cable gland and connect the wiring to the terminal strip as per your wiring diagram.

The color code is as per the details given below:

Terminal 1 (Common): Red

Terminal 2 (Normally closed): Black

Terminal 3 (Normally open): Yellow

CAUTION : Ensure that wires do not interfere with the operating mechanism. Please use earthing terminals that have been provided, one inside the enclosure and one outside.

Fig. 1.2

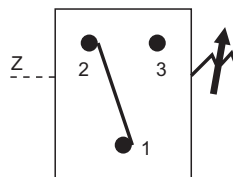

OPERATING TEMPERATURES:

The operating condition temperature restrictions for the MT series Temperature switch are as follows:

Operating Ambient : (-)5°C to +60°C

Note: Switches with temperature ranges beyond the ones specified above can be supplied on request.

Storage: -5°C to +60°C

SETTING AND CALIBRATION

Prior to dispatch, switches are checked to ensure the adjustment range is achieved and when requested preset at a specified value against a calibrated test instrument. A switch has tamperproof adjustment accessed by removal of the main cover. Adjustment to the set point is carried out by rotating the nut/shaft to the left to increase or to the right for decreasing the load respectively.

ROUTINE MAINTENANCE:

Routine inspection of the installation should take place at regular intervals. It is recommended that the switch is checked and operated every 5 months. Electrical connections and covers should be checked periodically for tightness. It is recommended that the 'O' rings and diaphragms be renewed every 3-5 years, and microswitch assemblies every 5-10 years dependant upon equipment usage.

SET POINT ADJUSTMENT:

Refer figure.

1. ISOLATE SUPPLY. Remove the cover.
2. Adjust the desired set point on the scale.
3. Apply the desired temperature to the sensing bulb of the switch.
4. Some minor adjustment will be required to achieve the exact point, which can be checked with the help of a proper temperature measurement device.
5. Replace the cover.

Tip : The temperature switches are factory set at half the set point range (unless otherwise specified in a Purchase Order).

TROUBLE SHOOTING TIPS

WARNING: Isolate the switch electrically and disconnect from pressure source before carrying out trouble shooting, in a safe area. Generally no problems are observed if the temperature switch selection, wiring and the set point is proper. For a temperature switch selection procedure, please consult our sales office.

For properly selected temperature switches, if

following symptoms are observed, the likely causes and remedies are as stated below.

SYMPTOM 1: SWITCH DOES NOT OPERATE

1) Wiring may not be correct, Check electrical connections to the temperature switch, if they are as per the wiring diagram.

2) The temperature bulb does not sense temperature.

DO NOT TAMPER THE TEMPERATURE BULB IN ANY EVENT.

If the cause is none of the above-mentioned probabilities, proceed as per the following steps.

Check the system temperature & set point of temperature switch.

For use of temperature switch for falling set points, system temperature has to be greater than the cut out point.

For use of temperature switch for rising set points, the system temperature may not be reaching the cutout point.

If the switch still does not operate, remove the temperature switch physically from the system. There should be continuity between terminals 1 & 2. If no continuity is observed the temperature switch should be returned to the factory.

SYMPTOM 2: LEAKAGE

In case leakage is observed, the temperature switch has to be returned to the factory without tampering the temperature bulb.

SPARES AND PART REPLACEMENTS :

We strongly recommend for spares and part replacement, kindly contact Kaustubha Udyog, Pune, India. ■